

Excellence Forever...



**EXCLUSIVE QUARTZ
KITCHEN SINK**



Dear Customer,

We invite you to experience the delightful amalgamation of art and technology. Come and learn about the exclusive range of composite quartz kitchen sink made with high precision and absolute perfection.

India's first ever Quartz Kitchen Sink enhanced with Shine Lock Technology that maintains the natural shine of the Surface even after intensive use.

The manufactured Quartz Kitchen Sink fits at every premises, whether it is a 5-Star Hotel or an Elegant Bungalow and even a small yet Stylish Studio Apartment. We provide colors, size and surface that fits your choice.

So, explore your taste of luxury...

when simplicity mixes with luxury it is spelled.

GT-1

SubhCera Corporation

TOP VIEW

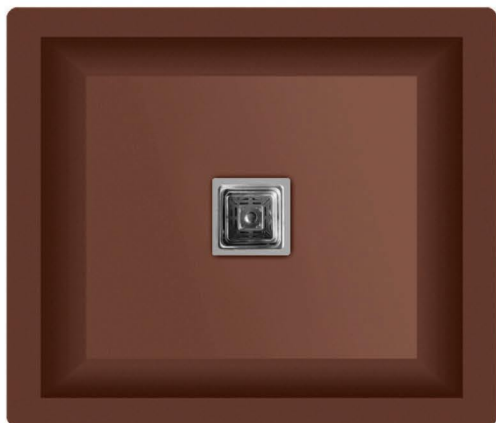

DIMENSIONS

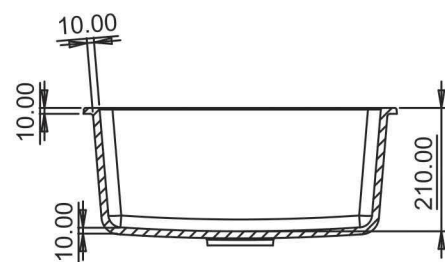
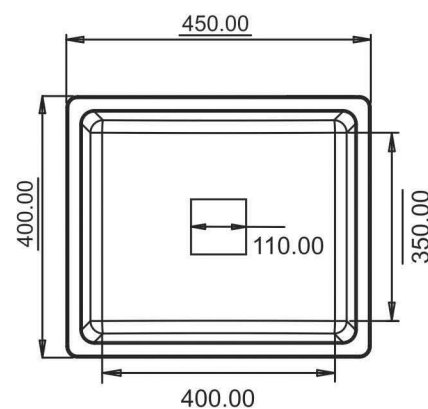

SIZE	WIGHT	M.R.P	
		GRANITE	METALLIC
16"X18"	8kg.(Aprx.)	5390/-	6495/-

Installation

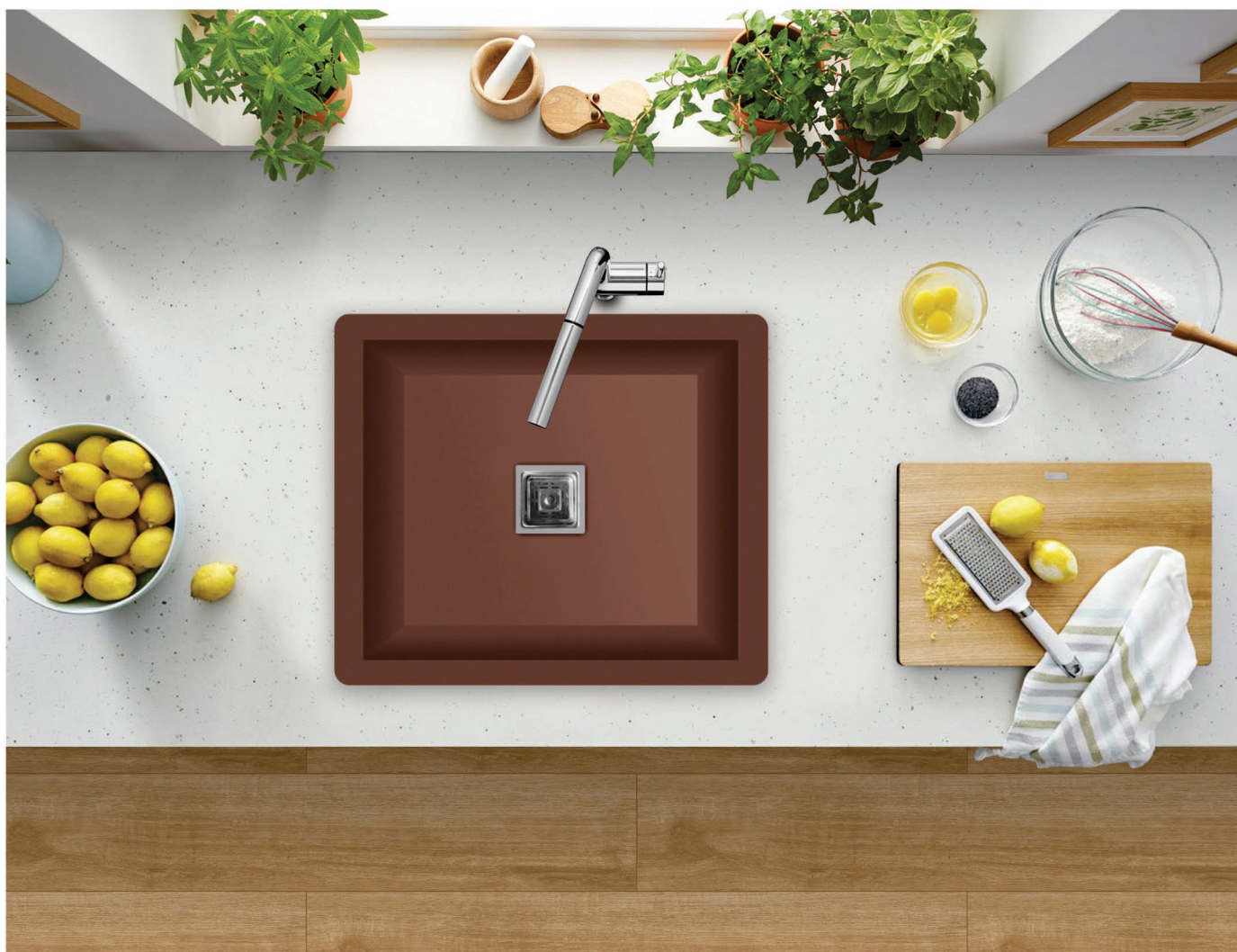

GT-2

SubhCera Corporation

TOP VIEW



DIMENSIONS

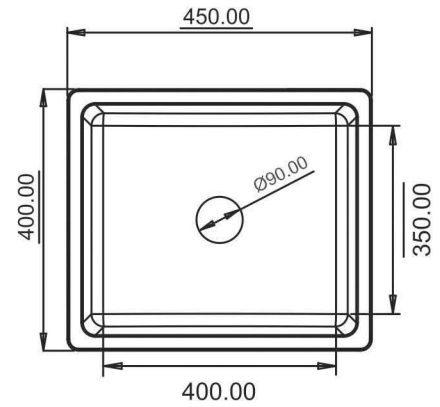

SIZE	WIGHT	M.R.P	
		GRANITE	METALLIC
16"X18"	8kg.(Aprx.)	5340/-	6440/-

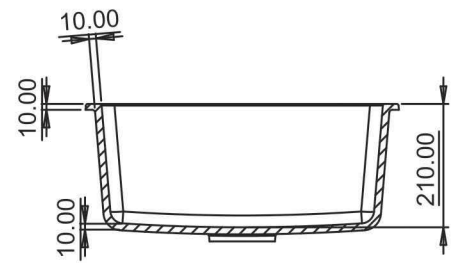

Installation



SOLO-S 1

SubhCera
Corporation

TOP VIEW



DIMENSIONS

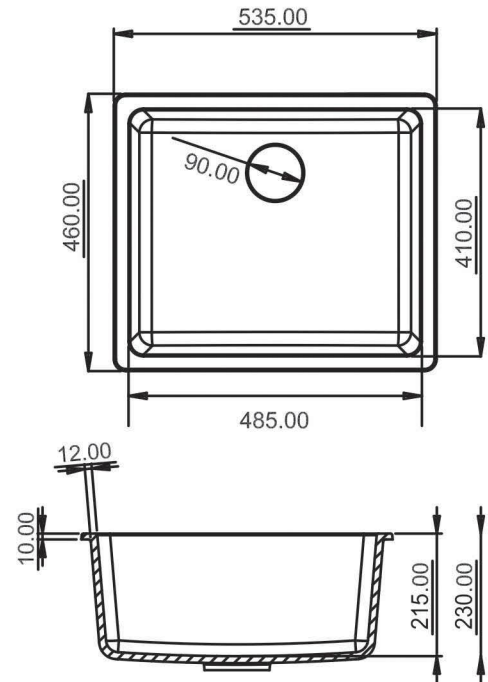

SIZE	WIGHT	M.R.P	
		GRANITE	METALLIC
21"X18"	11.5kg.(Aprx.)	6250/-	7550/-

Installation



SOLO-S2

SubhCera Corporation

TOP VIEW

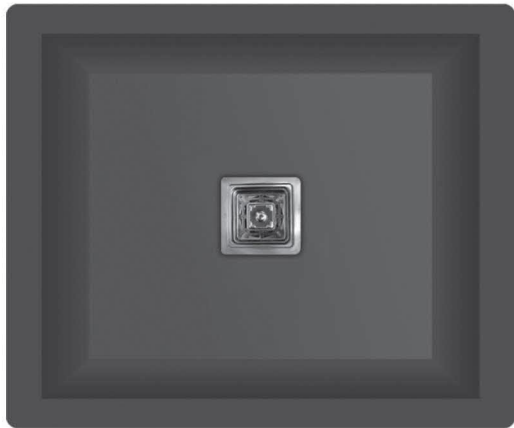

DIMENSIONS

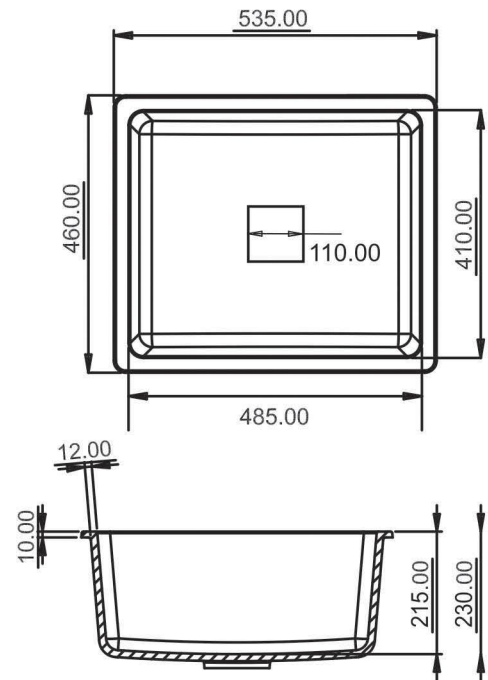

SIZE	WIGHT	M.R.P	
		GRANITE	METALLIC
21"X18"	11.5kg.(Aprx.)	6250/-	7550/-

Installation



VEGA-V2

SubhCera
Corporation

TOP VIEW



DIMENSIONS

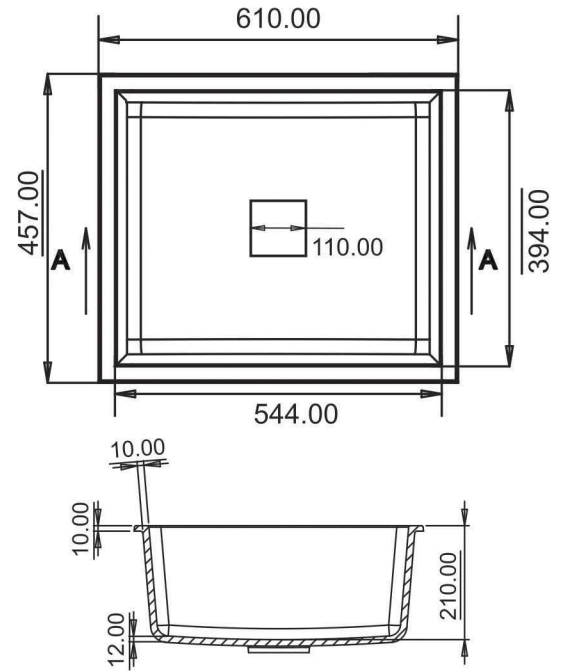

SIZE	WIGHT	M.R.P	
		GRANITE	METALLIC
24"X18"	11.9kg.(Aprx.)	6700/-	8210/-

Installation



VEGA-V3

SubhCera
Corporation

TOP VIEW

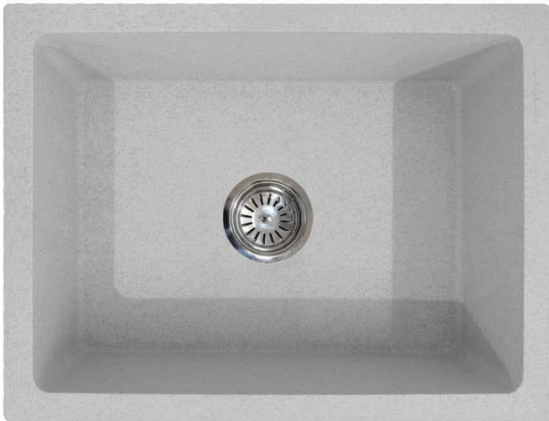

DIMENSIONS

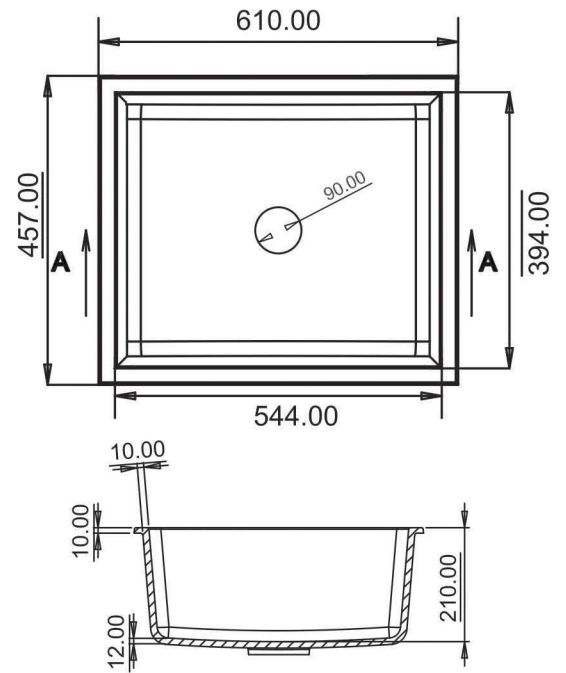

SIZE	WIGHT	M.R.P	
		GRANITE	METALLIC
24"X18"	12.3kg.(Aprx.)	6550/-	8050/-

Installation



ARIEL-A 1

SubhCera
Corporation

TOP VIEW



DIMENSIONS

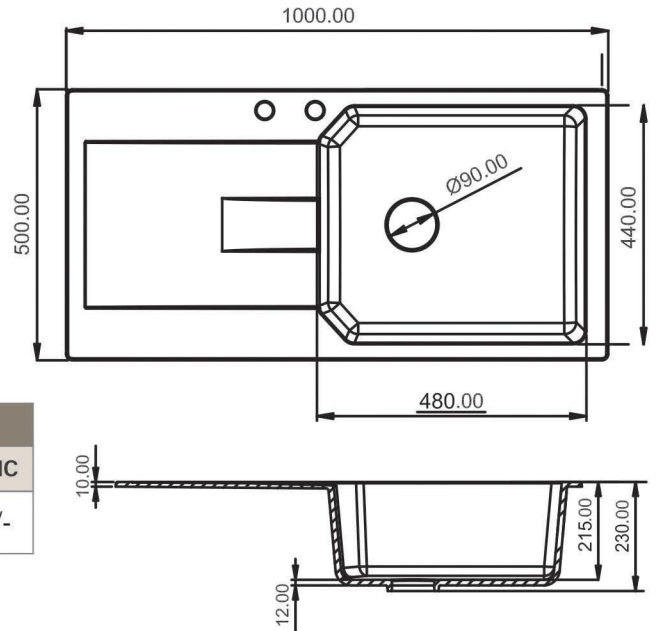

SIZE	WIGHT	M.R.P	
		GRANITE	METALLIC
39"X19.5"	18.3kg.(Aprx.)	11225/-	13575/-

Installation



EROS-E 1

SubhCera
Corporation

TOP VIEW



DIMENSIONS

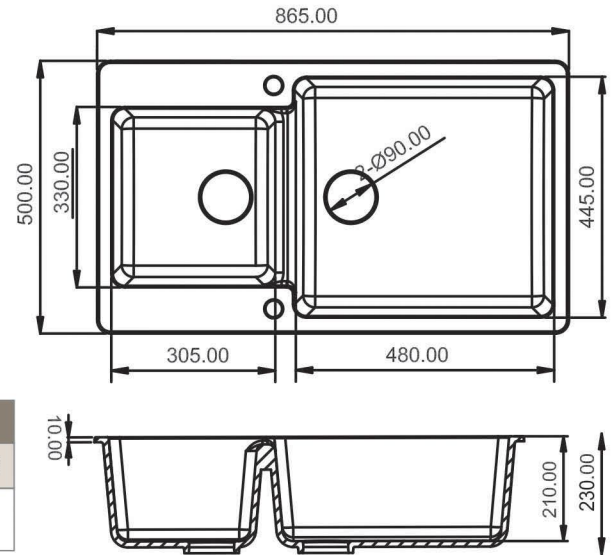

SIZE	WIGHT	M.R.P	
		GRANITE	METALLIC
34"X19.5"	22kg.(Aprx.)	11850/-	14150/-

Installation



RUGA

SubhCera
Corporation

TOP VIEW



DIMENSIONS

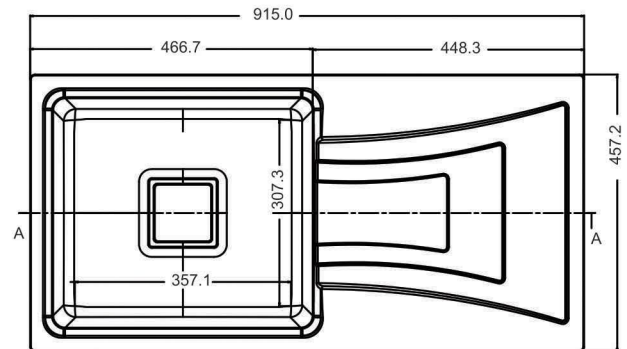

SIZE	WIGHT	M.R.P	
		GRANITE	METALLIC
36"X18"	18.5kg.(Aprx.)	11400/-	13600/-

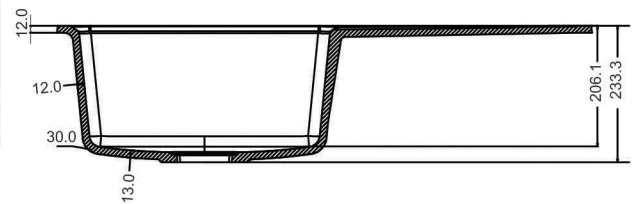

Installation



BOSS

SubhCera Corporation

TOP VIEW

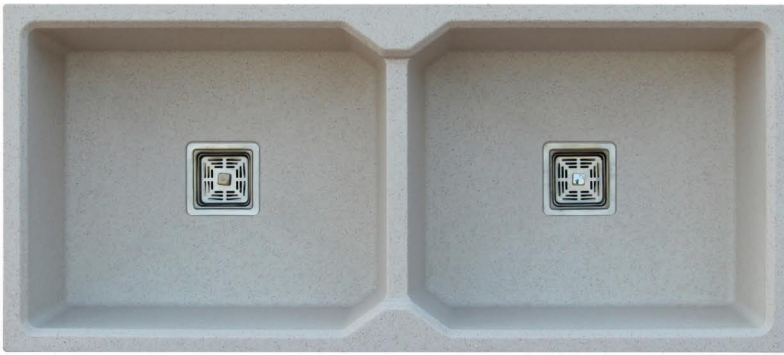

DIMENSIONS

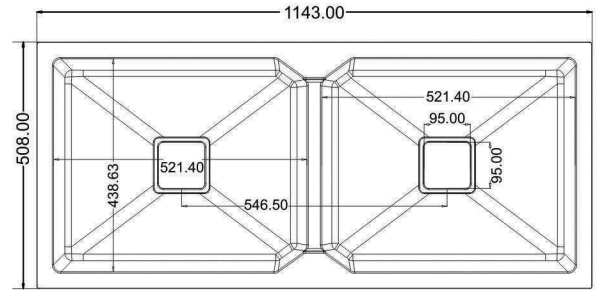

SIZE	WIGHT	M.R.P	
		GRANITE	METALLIC
45"X20"	30.5kg.(Aprx.)	22400/-	24600/-

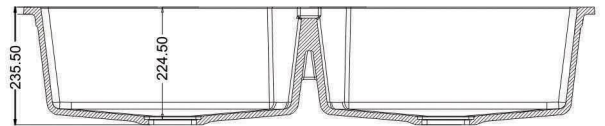

Installation



AMAZON

SubhCera Corporation

TOP VIEW

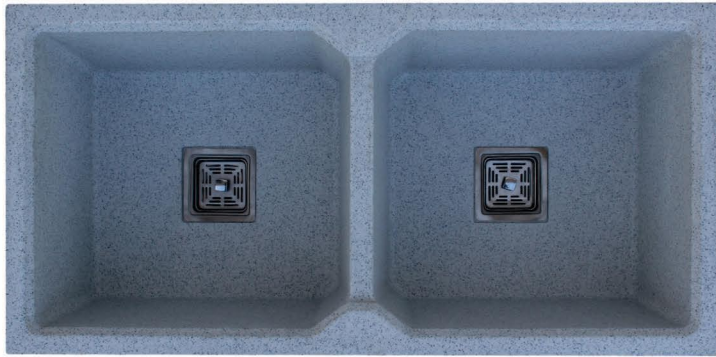

DIMENSIONS

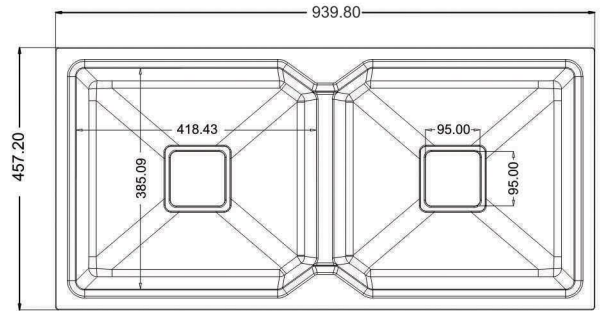

SIZE	WIGHT	M.R.P	
		GRANITE	METALLIC
37"X18"	22kg.(Aprx.)	15800/-	17200/-

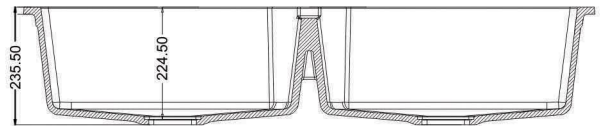

Installation

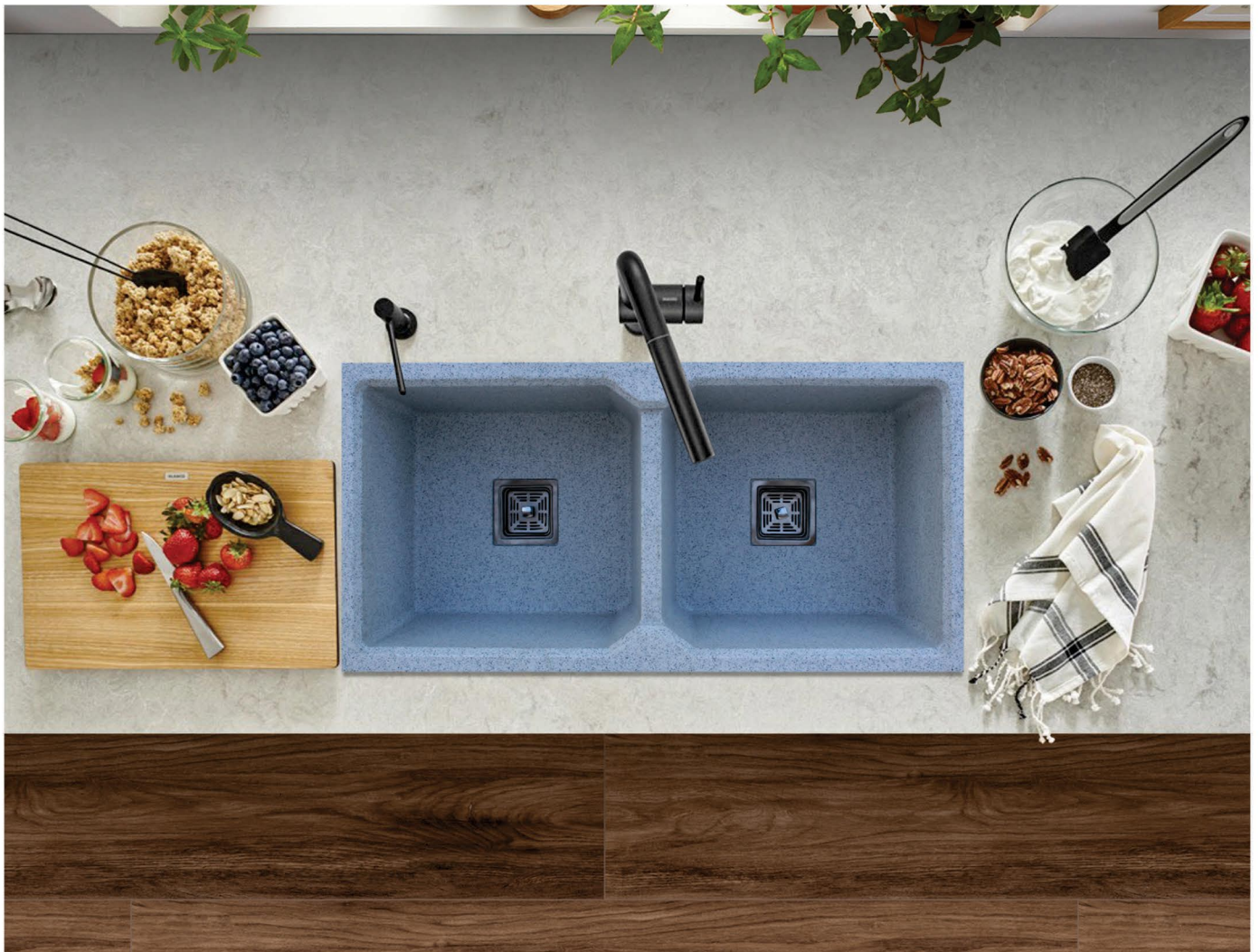

Available Colors

METALLIC SERIES

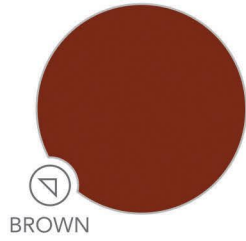
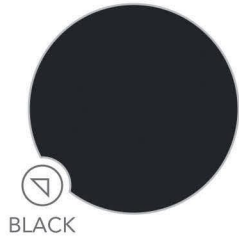
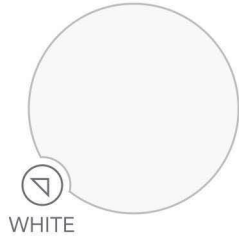

GRANITE SERIES

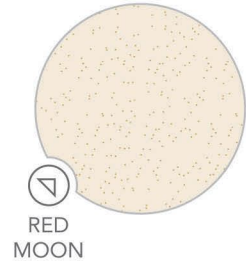
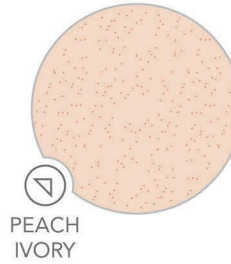
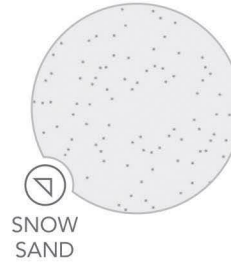

Installation



Features of Quartz Kitchen Sink



Disclaimer:

The Colours / Shade shown of sinks in this catalogue are purely illustrative and limited to printing process. Please refer actual sample before final selection. In case of any complaint, it should be brought to our Dealer notice before laying the sink. All sizes/prices are subject to change without prior notice. Please Refer MM size before Installation. All specifications are approximate and can vary in actual product. All Product shown is Identical and may vary from the actual product. This catalogue super seeds all previous catalogues. All products shown are not part of standard offering & props depicted are for aesthetics purpose only. Subject to Morbi (India) Jurisdiction.

Subh Cera Corporation

📍 Corporate office address :

SUBH CERA CORPORATION

Axar Complex, Office No-112,
Survey No-45, Plot No-57,
Behind Shakti Chamber,
Opp. G.S.P.C Gas Office,
8-A, National Highway, At- Trajpar,
Morbi-363 642 (Gujarat) INDIA

☎ + 91- 78788 73730 / 78745 73730

✉ subhceracorporation@gmail.com

